



MED

MINE EXTRACTION DEVICE



Available in 150, 210 and 360 tonne rated capacities

Elphinstone Mine Extraction Device (MED)
elphinstone.com

ELPHINSTONE

UNDERGROUND RELIABILITY



ELIMINATES UNSAFE EXTRACTIONS

Use fit-for-purpose equipment during extractions

The Elphinstone Mine Extraction Device (MED) has been designed, manufactured and engineer certified with a pulling capacity of up to 360 Tonnes.

The Mine Extraction Device was invented in response to requests from underground miners having difficulties extracting bogged equipment without damaging the mine or negatively impacting production.

The MED has performed hundreds of successful extractions at a number of underground mining operations (both coal and hard rock) across Australia and internationally.

Minimises disruptions to mining operations

Production disruptions are minimised by eliminating the need to deploy production equipment to assist in recoveries as well as minimising interactions with bogged or buried equipment.

The MED eliminates the need for traditional recovery methods that involve the use of other mobile equipment,

which reduces the hazards associated with personnel working around mobile equipment in close quarters and allows other mining operations to continue relatively uninterrupted.

What makes the MED so unique?

The Mine Extraction Device does not rely on traction like other systems. After the MED is towed into position, the boom is raised against the roof and the wheels are lowered on the floor. A bridle is interlocked onto the teeth of the MED racks. These MED racks are then pulled via hydraulic cylinders.

This is in contrast to using wheeled or tracked tow vehicles that can result in damage to the machines, the mine wall or floor or all of these in an attempted extraction process, all of which can add further delays to the restart of production.

Insurance supports the proven MED system

The unique retrieval system has the support of numerous insurance companies with the recognition that if this system cannot retrieve a buried loader then the loader is not retrievable.



PULLER CAPABILITIES & SPECIFICATIONS

Three power-packed levels of pulling capacity

The Mine Extraction Device is available in 150-tonne, 210-tonne, and 360-tonne capacities. The MED150, MED210, and MED360 were developed in line with industry growth.

In addition to the retrieval of buried equipment, the higher capacity models are also capable of extracting drill rods embedded in the rock face.

Features Include:

- » Pulling capacity of up to 360 Tonnes.
- » The extendable boom allows use in a range of underground operations.
- » Easily towed into place.
- » Operating pressure (Max) 180 Bar, flow rate of 6-70 litres per minute.
- » Control pedestal and pilot valve.
- » Optional remote control.
- » Winch to assist rack positioning.
- » Cranes to assist positioning racks (MED360 only)





MED360

Operating Pressure (Max)	180 Bar
Operating Flow Rate	6 - 70 l/min

MED210

Operating Pressure (Max)	180 Bar
Operating Flow Rate	6 - 70 l/min

MED150

Operating Pressure (Max)	180 Bar
Operating Flow Rate	6 - 70 l/min

Standard and Optional Equipment

Part Number	Description	Qty	MED150	MED210	MED360
360MEDV1-600	Arm Lift Ram Safety Lock	1			●
22137-03000	Base Machine, MED150	1	●		
24314-03000	Base Machine, MED210	1		●	
360MED-100	Base Machine, MED360	1			●
22137-04150-B	Boom Extension, MED150, 4m	1	●		
22137-03011-B	Boom Extension, MED150, 5m	1	●		
22137-03010-C	Boom Extension, MED150, 6m	1	●		
24314-06150	Boom Extension, MED210, 4m	1		●	
24314-04150	Boom Extension, MED210, 5m	1		●	
24314-400-1	Boom Extension - MED210, 6m	1		●	
360MEDV1-253	Boom Extension - MED360, 6m	1			●
360MED-189	Boom Extension, Adjustment Link	1			●
28324-162/A	Connecting Link, D-shackle	1	●	●	
24645-03150	Connecting Link, Sling	1	●	●	
360MED-179	Connecting Link, D-shackle	1			●
360MED-178	Connecting Link, Sling	1			●
	Control Bank, MED150	1	●		
210MED-176	Control Bank, MED210	1		●	
360MED-176	Control Bank, MED360	1			●
24314-03154	Head Plate, MED150, Flat	1	●		
24314-03165	Head Plate, MED150, Curved	1	●		
24314-03154	Head Plate, MED210, Flat	1		●	
24314-03165	Head Plate, MED210, Curved	1		●	
360MED-153	Head Plate, MED360, Flat	1			●
360MED-171	Head Plate, MED360, Curved	1			●
22137-03008	Hose Storage Rack, MED150	1	●		
28324-167	Hose Storage Rack, MED210	1		●	
360MEDV1-176	Hose Storage Rack, MED360	1			●
	Hydraulic Hoses, Machine to Control Bank	10m	●	●	●
	Hydraulic Hoses, Control Bank to Power Pack	10m	●	●	●
	Hydraulic Power Pack	1	●	●	●
	Hydraulic Winch	1	●	●	●
22137-03006/B	Rack, MED150, 2m	1	●		
22137-03006/E	Rack, MED150, 1m	10	●		
24314-03155/B	Rack, MED210 1m	10		●	
360MEDV1-156	Rack, MED360 1m	10			●
22137-03007/H	Rack, MED150, Pin	10	●		
24314-03157/H	Rack, MED210, Pin	10		●	
360MEDV1-178	Rack, MED360, Pin	10			●
22137-03009	Rack, Transport box, MED150	1	●		
24742-03000	Rack, Transport box, MED210	1		●	
360MED-177	Rack, Transport box, MED360	1			●
28324-906	Rack, Lifting Tool	1	●	●	
360MED-187	Rack, Lifting Bar, MED360	1			●
29924-001	Shipping Container, 20 foot	1	●	●	
29924-001	Shipping Container, 20 foot	2		●	●
24314-03161/A	Tow Bar	1		●	
24314-03162/D	Tow Bar, Connection Pin	1		●	
360MEDV1-255/A	Tow Bar	1			●
360MEDV1-256/A	Tow Bar, Connection Pin	1			●



MACHINE DIMENSIONS

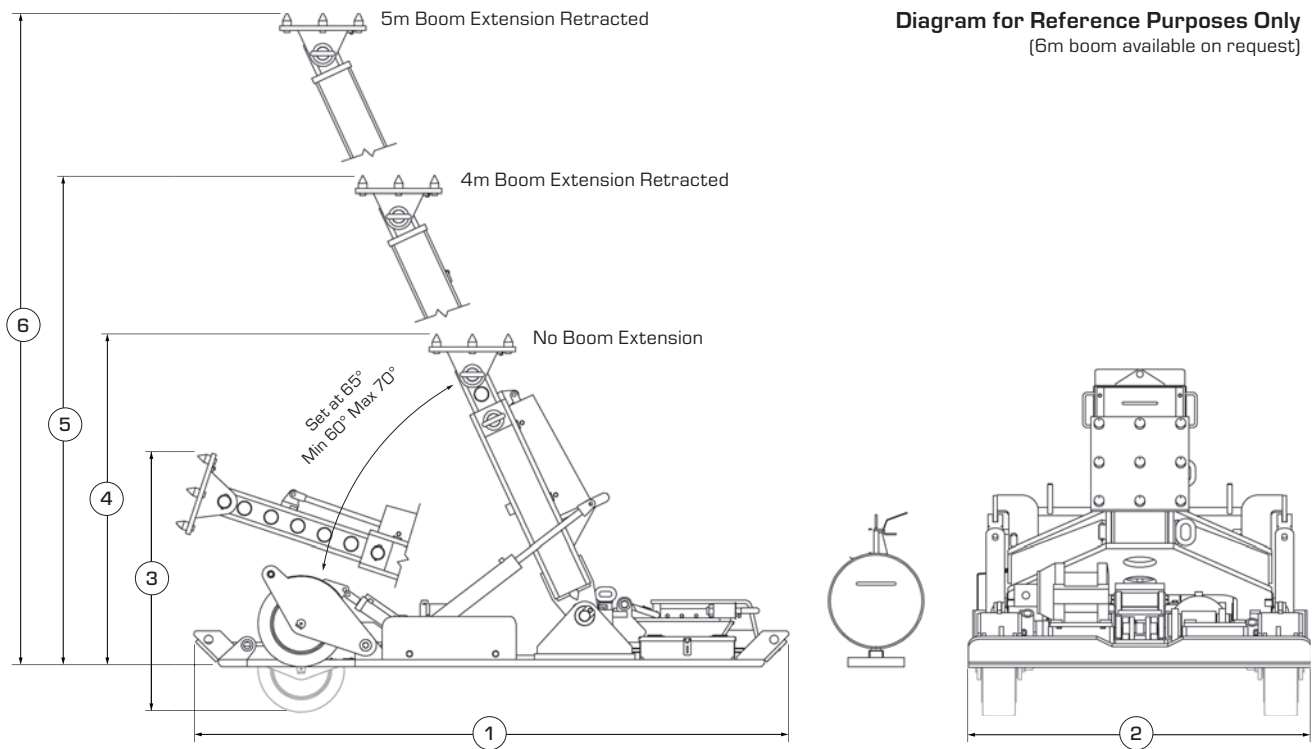

Diagram for Reference Purposes Only
(6m boom available on request)

Dimensions		MED150	MED210	MED360
1	Length	3246 mm	4142 mm	4720 mm
2	Width	1820 mm	2100 mm	2300 mm
3	Height - Ground to Head Plate - Retracted for Transport	1610 mm	1830 mm	1940 mm
4	Height - Retracted (No Boom Extension)	Nom. at 70°	2285 mm	2285 mm
		Nom. at 65°	2225 mm	2225 mm
		Nom. at 60°	2150 mm	2150 mm
Height - Extended (No Boom Extension)	Nom. at 70°	3035 mm	3035 mm	
	Nom. at 65°	2950 mm	2950 mm	
	Nom. at 60°	2840 mm	2840 mm	
5	Height - Retracted with Standard 4m Boom Extension	Nom. at 70°	3430 mm	4095 mm
		Nom. at 65°	3325 mm	3985 mm
		Nom. at 60°	3200 mm	3845 mm
Height - Extended with Standard 4m Boom Extension	Nom. at 70°	4180 mm	4465 mm	
	Nom. at 65°	4050 mm	4340 mm	
	Nom. at 60°	3895 mm	4185 mm	
6	Height - Retracted with Standard 5m Boom Extension	Nom. at 70°	4600 mm	5495 mm
		Nom. at 65°	4460 mm	5335 mm
		Nom. at 60°	4285 mm	5135 mm
Height - Extended with Standard 5m Boom Extension	Nom. at 70°	5165 mm	5885 mm	
	Nom. at 65°	5000 mm	5710 mm	
	Nom. at 60°	4800 mm	5490 mm	
	Height - Ground to HIAB Crane Knuckle (Packed Up - MED360 only)	N/A	N/A	2195 mm
Weights		MED150	MED210	MED360
Machine Total Mass*		6000 kg	7355 kg	13,000 kg
Rack (1000 mm)		89 kg	103 kg	144 kg
Rack (2000 mm)		172 kg	-	-
Pin		6 kg	6 kg	11 kg
Rack Box		325 kg	325 kg	660 kg

*Total mass excludes vendor parts

OVER 45 YEARS IN THE MINING INDUSTRY.

Elphinstone Pty Ltd is an established Caterpillar Original Equipment Manufacturer with over 45 years' experience in the mining industry. Elphinstone specialises in the design, manufacture and support of quality equipment for the global underground and surface mining industries.

The Elphinstone range of Underground Mining Support Vehicles combines practical design, the latest technology and quality manufacturing to ensure reliable performance.

The current product range includes specialised underground support vehicles, mine extraction devices, extended distance off-highway haulage trucks and water tanks customised to suit Caterpillar articulated trucks.

As an authorised Caterpillar Original Equipment Manufacturer, all Elphinstone products are sold and supported via the global Cat® dealer network.

MED - MINE EXTRACTION DEVICE

For more complete information on Elphinstone products, dealer services, and industry solutions, visit www.elphinstone.com or contact your local Cat dealer.

Material and specifications are subject to change without notice. Featured machines in photos may include additional equipment.

Elphinstone and their respective logos, as well as corporate and product identity used herein, are trademarks of Elphinstone and may not be used without permission.

© 2024 Elphinstone. All rights reserved.
Made in Australia for export.

ELPHINSTONE



HM62782-05 [01-2024]